



SPO# \_\_\_\_\_

CUSTOMER: \_\_\_\_\_

PROJECT: \_\_\_\_\_

TRENCH

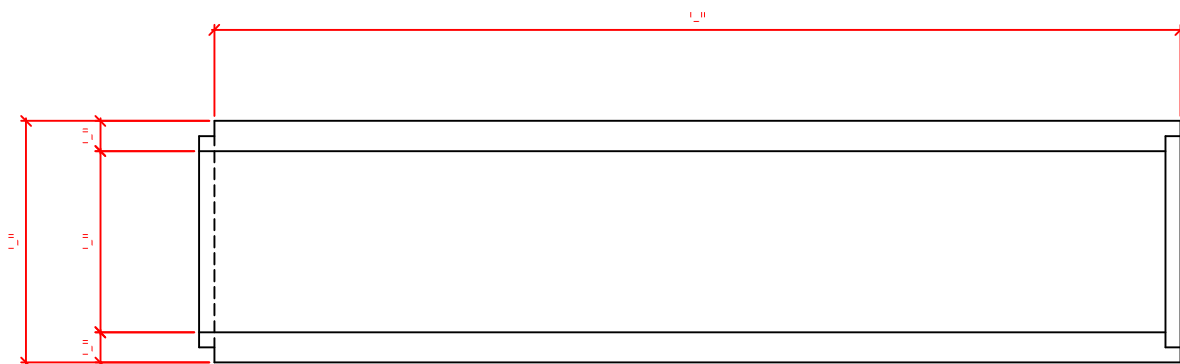

PLAN VIEW

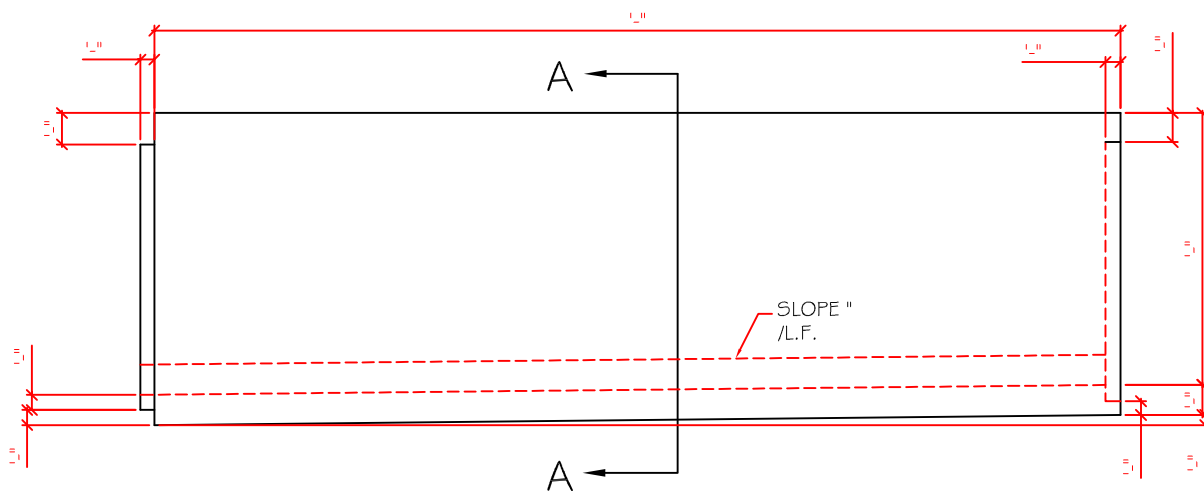

ELEVATION

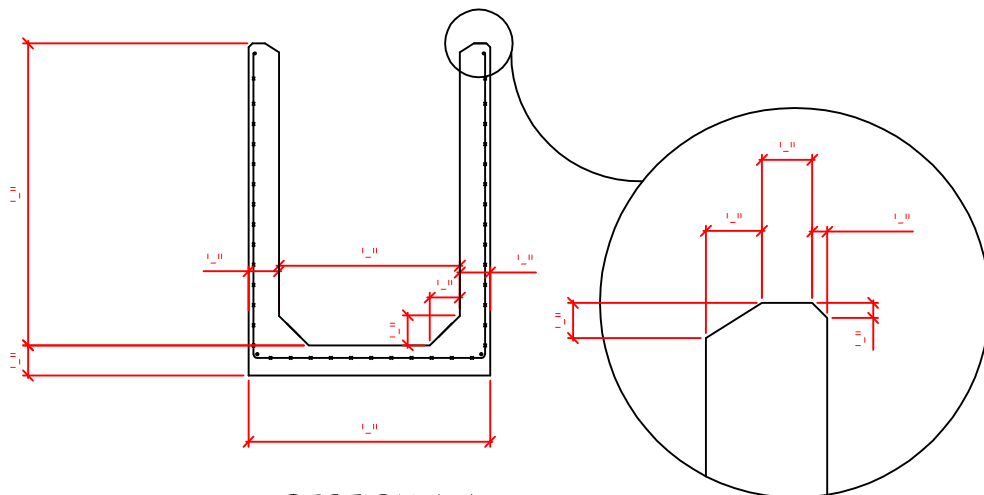

SECTION A-A

UNITED PRECAST INC.  
P.O. BOX 991  
MT. VERNON, OHIO 43050